



## 4.6 过渡接头

## 4.6·过渡接头

### 4.6·Transition Fittings

🛒 订购号 / Order

BD	G01				- 02					
型号 \ model	①				②					
①		英制锥管螺纹 / Taper Pipe Thread				英制直管螺纹 / G Thread				公制螺纹 / Metric Thread
	- 代号 / Code	01	02	03	04	G01	G02	G03	G04	M5
	螺纹尺寸 / Thread Size	R1/8	R1/4	R3/8	R1/2	G1/8	G1/4	G3/8	G1/2	M5×0.8
②	螺纹和①相同时省略: 例 CEF-G01/Elimination of the same threads : Example CEF-G01									

BA 内螺纹直通	MODEL	G	G1	L	🔩
	BA-G01	G1/8	G1/8	17	13
	BA-G02	G1/4	G1/4	23	16
	BA-G03	G3/8	G3/8	25.5	20
	BA-G04	G1/2	G1/2	30	24
	BA-G02G01	G1/4	G1/8	20	16
	BA-G03G01	G3/8	G1/8	21	20
	BA-G04G01	G1/2	G1/8	23	24
	BA-G03G02	G3/8	G1/4	23	20
	BA-G04G02	G1/2	G1/4	25	24
	BA-G04G03	G1/2	G3/8	26	24

BD 内外螺纹直通	MODEL	G	R	L	L1	L2	🔩
	BD-G0102	G1/8	R1/4	14.5	9.5	8.5	14
	BD-G0103	G1/8	R3/8	15.5	10.5	8.5	17
	BD-G0104	G1/8	R1/2	19	13.5	8.5	21
	BD-G0203	G1/4	R3/8	15.5	10.5	10	17
	BD-G0204	G1/4	R1/2	19	13.5	11	21
	BD-G0304	G3/8	R1/2	19	13.5	12	21

BB 双外螺纹直通	MODEL	R	R1	L	L1	L2	🔩
	BB-01	R1/8	R1/8	19.5	7.5	7.5	10
	BB-02	R1/4	R1/4	24	9.5	9.5	14
	BB-03	R3/8	R3/8	26.5	10.5	10.5	17
	BB-04	R1/2	R1/2	33	13.5	13.5	21
	BB-0102	R1/8	R1/4	22	7.5	9.5	14
	BB-0103	R1/8	R3/8	23	7.5	10.5	17
	BB-0104	R1/8	R1/2	26	7.5	13.5	21
	BB-0203	R1/4	R3/8	25.5	9.5	10.5	17
	BB-0204	R1/4	R1/2	28	9.5	13.5	21
	BB-0304	R3/8	R1/2	29	10.5	13.5	21

## 4.6·过渡接头

### 4.6·Transition Fittings

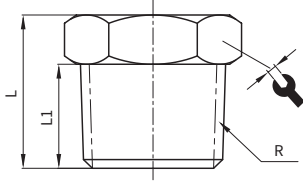
		MODEL	R	L	L1	⚙️
		BZ-01	R1/8	11	7.5	10
		BZ-02	R1/4	14	9.5	14
		BZ-03	R3/8	15.5	10.5	17
		BZ-04	R1/2	19	13.5	21

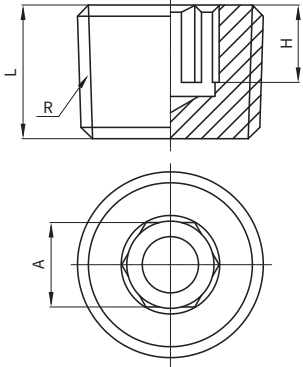
		MODEL	R	L	H	A
		BP-01	R1/8	8	4.5	5
		BP-02	R1/4	10	5.5	6
		BP-03	R3/8	10.5	6	8
		BP-04	R1/2	13.5	8	10

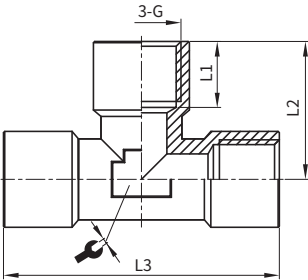
		MODEL	G	L1	L2	L3	⚙️
		CEF-G01	G1/8	8.5	18	36	12
		CEF-G02	G1/4	11	23	46	14
		CEF-G03	G3/8	12	25.5	51	16
		CEF-G04	G1/2	14	30.5	61	17

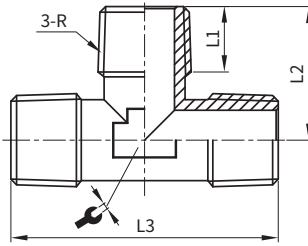
		MODEL	R	L1	L2	L3	⚙️
		CET-01	R1/8	7.5	15	30	9
		CET-02	R1/4	9.5	19	38	10
		CET-03	R3/8	10.5	22.5	45	14
		CET-04	R1/2	13.5	28.5	57	17

## 4.6·过渡接头

### 4.6·Transition Fittings

 CL-FM		MODEL	R	G	L1	L2	L3	L4	⚙️
		CLFM-G0101	R1/8	G1/8	7.5	8.5	16	19	10
		CLFM-G0202	R1/4	G1/4	9.5	11	21	23	11
		CLFM-G0303	R3/8	G3/8	10.5	12	23	27.5	14
		CLFM-G0404	R1/2	G1/2	13.5	14	28	31	17

 CLF		MODEL	G	L	L1	⚙️
		CLF-G01	G1/8	8.5	18	9
		CLF-G02	G1/4	11	23	11
		CLF-G03	G3/8	12	25.5	13
		CLF-G04	G1/2	14	30.5	17

 CL		MODEL	R1	R2	L1	L2	L3	L4	⚙️
		CL-01	R1/8	R1/8	7.5	16	7.5	16	7
		CL-02	R1/4	R1/4	9.5	20	9.5	20	10
		CL-03	R3/8	R3/8	10.5	23	10.5	25	14
		CL-04	R1/2	R1/2	13.5	28.5	13.5	28.5	17
		CL-0102	R1/8	R1/4	7.5	17	9.5	19	10
		CL-0103	R1/8	R3/8	7.5	19	10.5	22.5	12
		CL-0203	R1/4	R3/8	9.5	21	10.5	22.5	12
		CL-0204	R1/4	R1/2	9.5	22.5	13.5	27.5	12
		CL-0304	R3/8	R1/2	10.5	23	13.5	28	14

## 4.6·过渡接头

### 4.6·Transition Fittings

 BB-G		MODEL	G	G1	L	L1	L2	🔩
		BB-M5	M5	M5	13	3.5	3.5	8
		BB-G01	G1/8	G1/8	17	5.5	5.5	13
		BB-G02	G1/4	G1/4	19.5	6.5	6.5	16
		BB-G03	G3/8	G3/8	22	7.5	7.5	20
		BB-G04	G1/2	G1/2	26	9	9	24
		BB-G01G02	G1/8	G1/4	18.5	5.5	6.5	16
		BB-G01G03	G1/8	G3/8	20	5.5	7.5	20
		BB-G02G03	G1/4	G3/8	21	6.5	7.5	20
		BB-G02G04	G1/4	G1/2	23.5	6.5	9	24
		BB-G03G04	G3/8	G1/2	24.5	7.5	9	24

 BB		MODEL	R	R1	L	L1	L2	🔩
		BB-01	R1/8	R1/8	19.5	7.5	7.5	10
		BB-02	R1/4	R1/4	24	9.5	9.5	14
		BB-03	R3/8	R3/8	26.5	10.5	10.5	17
		BB-04	R1/2	R1/2	33	13.5	13.5	21
		BB-0102	R1/8	R1/4	22	7.5	9.5	14
		BB-0103	R1/8	R3/8	23	7.5	10.5	17
		BB-0104	R1/8	R1/2	26	7.5	13.5	21
		BB-0203	R1/4	R3/8	25.5	9.5	10.5	17
		BB-0204	R1/4	R1/2	28	9.5	13.5	21
		BB-0304	R3/8	R1/2	29	10.5	13.5	21

 BZ-G		MODEL	G	L	L1	🔩
		BZ-M5	M5	6.5	3.5	8
		BZ-G01	G1/8	10.5	5.5	13
		BZ-G02	G1/4	12	6.5	16
		BZ-G03	G3/8	13.5	7.5	20
BZ-G04	G1/2	15.5	9	24		

中国 +86 400 101 8889	德国 +49 (30) 72088-0
美国 +01 630 995 3674	日本 +81 03 6809 1696



© 未经恒立气动公司授权，此宣传册任何部分不得以任何方式  
翻版、编辑、复制及使用电子方式进行传播。由于产品一直在  
不断开发创新中，本宣传册中信息不针对特定行业的特殊条件  
或适用性，对于因此而产生的任何不完整或不准确描述，恒立  
气动不承担责任。