



4.1

# M60V(E) SERIES

## Bent-axial Piston Variable Displacement Motor

The M60V & M60VE series bent-axial piston variable displacement motor is used in an open or closed circuit. The bent-axial structure ensures a larger displacement and a more compact structure under the same volume.

Apply to open or close circuit

Size:	28	60	85	115	160	170	200	215
Nominal pressure (bar):	400	450	450	450	400	450	400	450
Max. pressure (bar):	450	530	530	530	450	530	450	530



## Contents

Technical Data	02
Type introduction	03-05
Principle	06-12
Installation size	
· M60VE28	13-14
· M60V(E)60	15-18
· M60V(E)85	19-24
· M60V(E) 115	25-30
· M60V(E)160	31-32
· M60V(E) 170	33-36
· M60V(E) 200	37-38
· M60V(E) 215	39-40

## Features

- Flange and plug-in designs are optional to meet different installation methods.
- Higher pressure and higher speed
- Superior performance in low speed operation provides excellent controllability.
- High activation efficiency.
- Various controllers are optional.
- Wide control range (to an angle of 0° ).
- High torque and long service life.
- Flush valve and high-pressure balance valves are optional.
- Suitable for engineering machinery and general industrial vehicles, especially rotary drilling rigs and cranes.

## Technical Data

Size		28	60	85	115	160	170	200	215
Max displacement (cc/rev)		28	62	85.2	115.6	160	171.8	200	216.5
Min displacement (cc/rev)		0							
Direction of rotation		Clockwise, Counter clockwise							
Rotation speed (rpm) (Not at min. displacement)	Rated	5550	4450	3900	3550	3100	3100	2900	2900
	Max.	8750	7200	6800	6150	4900	4900	4600	4800
Rotation speed (rpm) (At min. displacement)	Max.	10450	8400	8350	7350	5500	5750	5100	5500
Pressure (bar)	Rated	400	450	450	450	400	450	400	450
	Max.	450	530	530	530	450	530	450	530
Max. output torque (N·m), ( $\Delta P=450\text{bar}$ )		179 ( $\Delta P=400\text{bar}$ )	444	610	828	1019 ( $\Delta P=400\text{bar}$ )	1230	1273 ( $\Delta P=400\text{bar}$ )	1550
Weight (Kg) (Approximate value)		21.5	31	39	46	67	62	78	78
Oil viscosity (mm <sup>2</sup> /s)		5 ~ 1600, Best range: 16~36							
Oil Temperature (°C)		-25 ~ 103							
Oil Cleanliness		ISO 4406 20/18/15							
Moment of inertia (kg·m <sup>2</sup> )		0.0014	0.0043	0.0072	0.0110	0.0253	0.0213	0.0353	0.0303

## Type Introduction

M60V	200	E6	D1	N	R	S4	A2	A	F	E	—	J
①	②	③	④	⑤	⑥	⑦	⑧	⑨	⑩	⑪		⑫

### Product series

	Product series	28	60	85	115	160	170	200	215	Code
①	Bent-axial Variable Piston Motor (Flange-type motor)	○	●	●	●	●	●	●	●	M60V
	Bent-axial Variable Piston Motor (Plug-in motor)	●	●	●	●	●	●	●	●	M60VE

### Displacement

②	Displacement (cc/rev)	28	60	85	115	160	170	200	215
---	-----------------------	----	----	----	-----	-----	-----	-----	-----

### Sensor

	Sensor	28	60	85	115	160	170	200	215	Code	
③	Electric proportional displacement control	positive characteristic, 12V	●	●	●	●	●	●	●	E1	
		positive characteristic, 24V	●	●	●	●	●	●	●	E2	
		negative characteristic, 12V	●	●	●	●	●	●	●	E5	
		negative characteristic, 24V	●	●	●	●	●	●	●	E6	
	Hydraulic proportional control	positive characteristic (ΔP=10bar)		●	●	●	●	●	●	●	H1
		positive characteristic (ΔP=25bar)		●	●	●	●	●	●	●	H2
		negative characteristic (ΔP=10bar)		●	●	●	●	●	●	●	H5
		negative characteristic (ΔP=25bar)		●	●	●	●	●	●	●	H6
	Automatic control high-pressure related	ΔP ≤ approx, 10bar		●	●	●	●	●	●	●	V1
		ΔP=100bar		●	●	●	●	●	●	●	V2

### Pressure cut-off

④	With	D1
	Hydraulic remote control, proportional	T3
	Without	00

### Speed sensor

⑤	With	S
	Without	N

## Type introduction

### Port position

	Port position	28	60	85	115	160	170	200	215	Code
⑥	Rear	●	●	●	●	●	●	●	●	R
	Side	●	●	●	●	●	●	●	●	A

### Mounting flange

	Mounting flange (M60V)	28	60	85	115	160	170	200	215	Code
⑦	125-4 ISO 3019-2		●							M4
	127-4 SAE J744			●						C4
	140-4 ISO 3019-2			●						N4
	152-4 ISO 3019-1					●	●			D4
	160-4 ISO 3019-2				●					P4
	180-4 ISO 3019-2					●	●			R4
	200-4 ISO 3019-2							●	●	S4
	Mounting flange (HME6V)	28	60	85	115	160	170	200	215	Code
	135-2 ISO 3019-2	●								L2
	160-2 ISO 3019-2		●							P2
	190-2 ISO 3019-2			●						Y2
	200-2 ISO 3019-2				●	●	●			S2
	260-4 ISO 3019-2							●	●	Z4

### Input shaft

	Drive shaft (M60V)	28	60	85	115	160	170	200	215	Code
⑧	W35×2×16×9g DIN 5480		●							Z8
	W40×2×18×9g DIN 5480			●	●					Z9
	W45×2×21×9g DIN 5480					●	●			A1
	W50×2×24×9g DIN 5480					●	●	●	●	A2
	13-8/16 ANSI J498b				●	●	●	●	●	A3
	14T-12-24 ANSI B92.1			●						S7
	21T-16/32 ANSI B92.1				●					Z1
27T-16/32 ANSI B92.1								●	A4	
	Drive shaft (HME6V)	28	60	85	115	160	170	200	215	Code
	W30×2×14×9g DIN 5480	●	●							Z6
	W40×2×18×9g DIN 5480			●	●					Z9
	W45×2×21×9g DIN 5480					●	●			A1
	W50×2×24×9g DIN 5480							●	●	A2

## Type introduction

### Seal type

⑨	O ring seal (ISO 6149)	A
	Elastomeric sealing (ISO 9974)	E

### Seal Method

⑩	Normal	F
	Cryogenic seal	N

### Balance valve

⑪	With balance valve, BVD	D
	With balance valve, BVE	E
	With balance valve, BVI	I
	Without	0

### Standard / special version

⑫	Standard version					0
	Special version	Second small displacement (optional only with balance valve)				V
		With flush valve	Flushing flow (L/min)	Code	Flushing flow (L/min)	Code
3.5			A	20	G	
5	B		25	H		
8	C		30	I		
10	D		35	J		
14	E		40	K		
17	F					

Remark: ● = Available; ○ = On request

# Principle

## · EP-Electric Proportional Control

The electric proportional displacement control valve is installed on the motor. The motor displacement is proportional to the electric control current applied to the solenoid.

### EP1, EP2

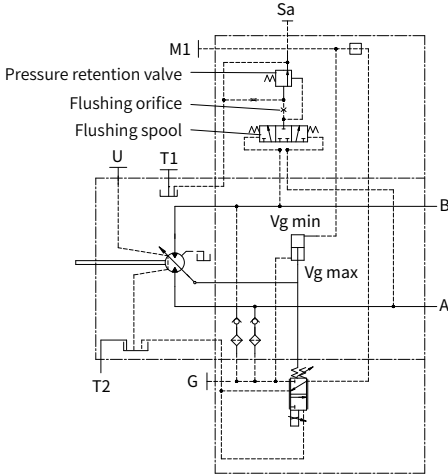

EP1, EP2 positive control  
 Beginning of control at Vg min  
 End of control at Vg max

### EP5, EP6

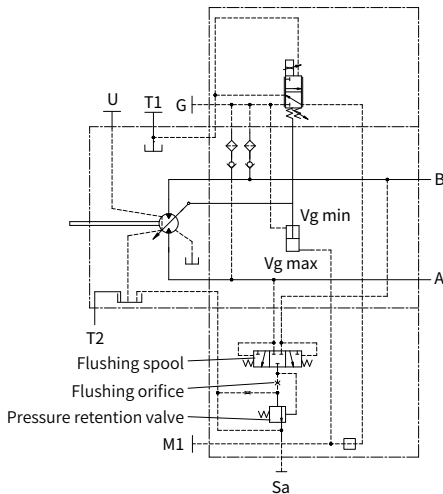

EP5, EP6 negative control  
 Beginning of control at Vg max  
 End of control at Vg min

# Principle

## • EP-Electric Proportional Control

The electric proportional displacement control valve is installed on the motor. The motor displacement is proportional to the electric control current applied to the solenoid.

**EP5D1**

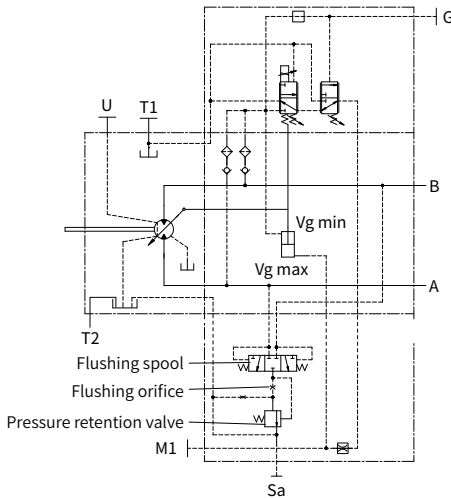

EP5 is negative electric proportional control with 12v solenoid, D1 is pressure control, If the load torque or a reduction in motor swivel angle causes the system pressure to reach the setpoint value of the pressure control, the motor will swivel towards a larger displacement. Setting range of the pressure control valve 80 to 450 bar.

Technical data, solenoid	EP1、EP5	EP2、EP6
Voltage/V	12	24
Control current/mA	400~1200	200~600
Current limit/A	1.3	0.65
Nominal Resistance (20°C) /Ω	5.7±0.5	23.5±7

## Principle

### · HP-Hydraulic Proportional Control

The hydraulic proportional displacement control valve is installed on the motor. The motor displacement is proportional to the pilot pressure, X is pilot pressure port.

#### HP1、HP2

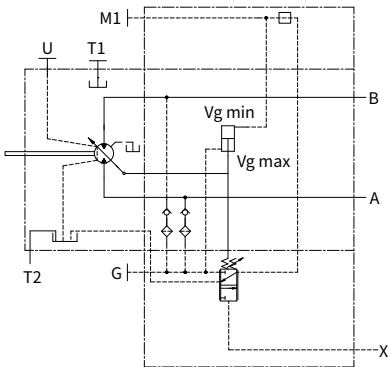

HP1(positive control, increment of pilot pressure is 10 bar). Beginning of control at  $V_g$  min, End of control at  $V_g$  max. The motor displacement will increase from minimum to maximum when pilot pressure increases by 10 bar. Setting range of the displacement change point of pilot pressure is 2 to 20 bar.

HP2(positive control, increment of pilot pressure is 25 bar). Beginning of control at  $V_g$  min, End of control at  $V_g$  max. The motor displacement will increase from minimum to maximum when pilot pressure increases by 25 bar. Setting range of the displacement change point of pilot pressure is 5 to 35 bar.

#### HP5、HP6

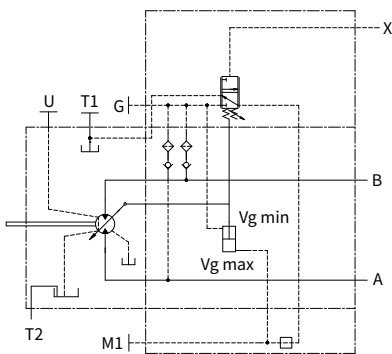

HP5(negative control, increment of pilot pressure is 10 bar). Beginning of control at  $V_g$  max, End of control at  $V_g$  min. The motor displacement will increase from maximum to minimum when pilot pressure increases by 10 bar. Setting range of the displacement change point of pilot pressure is 2 to 20 bar.

HP6(negative control, increment of pilot pressure is 25 bar). Beginning of control at  $V_g$  max, End of control at  $V_g$  min. The motor displacement will increase from maximum to minimum when pilot pressure increases by 25 bar. Setting range of the displacement change point of pilot pressure is 5 to 35 bar.



# Principle

## • HP-Hydraulic Proportional Control

The hydraulic proportional displacement control valve is installed on the motor. The motor displacement is proportional to the pilot pressure, X is pilot pressure port.

**HP5D1**

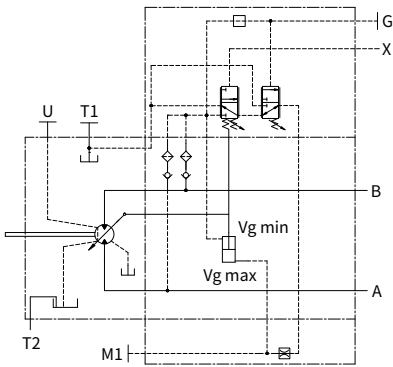

HP5D1(negative control, increment of pilot pressure is 10 bar+Pressure control valve). The hydraulic proportional displacement control valve and the pressure control valve are installed on the motor at the same time. HP5 is negative hydraulic proportional control with 10 bar increment of pilot pressure, D1 is pressure control, If the load torque or a reduction in motor swivel angle causes the system pressure to reach the setpoint value of the pressure control, the motor will swivel towards a larger displacement.Setting range of the pressure control valve 80 to 450 bar.

## • HA-Automatic High Pressure Related Control

Automatic high pressure related control means the motor displacement will change automatically according to the working pressure, the pilot pressure of control valve is supplied by motor working pressure from A or B port, no external control pressure is required. When the working pressure reached the setpoint valve of control valve, the motor will swivel towards a larger displacement. The displacement is modulated between Vg min and Vg max depending on the load.

**HA1**

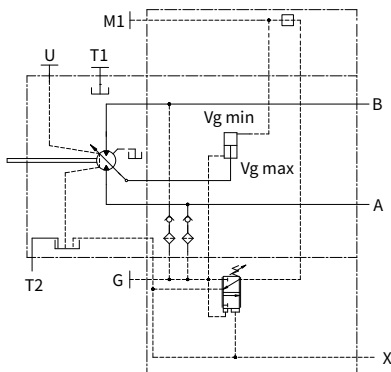

HA1(Automatic high pressure related control, increment of working pressure  $\Delta P \leq 10$  bar). Increment of working pressure  $\Delta P \leq 10$  bar, The motor displacement will increase from minimum to maximum. Setting range of the setpoint of control valve pressure is 80 ~ 350bar.

04

## Principle

### ·HA-Automatic High Pressure Related Control

Automatic high pressure related control means the motor displacement will change automatically according to the working pressure, the pilot pressure of control valve is supplied by motor working pressure from A or B port, no external control pressure is required. When the working pressure reached the setpoint valve of control valve, the motor will swivel towards a larger displacement. The displacement is modulated between  $V_g \text{ min}$  and  $V_g \text{ max}$  depending on the load.

#### HA2

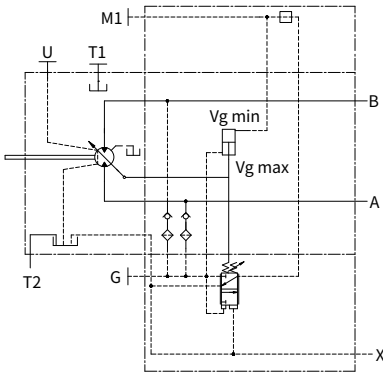

HA2(Automatic high pressure related control, increment of working pressure  $\Delta P \approx 100\text{bar}$ ). Increment of working pressure  $\Delta P \approx 100\text{bar}$ , The motor displacement will increase from minimum to maximum. Setting range of the setpoint of control valve pressure is 80 ~ 350bar.

#### HA2T3

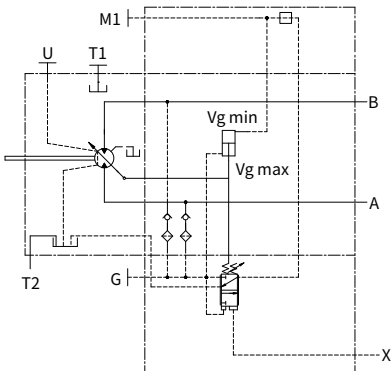

HA2T3(Automatic high pressure related control+remote pressure control, increment of working pressure  $\Delta P \approx 100\text{bar}$ ). For the HA2T3 control mode, in spite of working pressure from A or B port will provide the control valve pressure, the beginning of control can be influenced by applying a pilot pressure to port X. The beginning of control is reduced by 17 bar per 1 bar pilot pressure.

## Principle (With Counter Balance Valve )

### · HA1+BVD

### (Automatic High Pressure Related Control + Counter Balance Valve)

HA1+BVD(Automatic High Pressure Related Control + Counter Balance Valve, increment of working pressure  $\Delta P \leq 10$  bar, Spool of balance valve with internal orifice, control system has high pressure relief valves.)

S port is boost port, boost hydraulic fluid can reduce the risk that motor vacuums during braking. When the motor is working (fluid flows from port B to port A), balance valve opened, hydraulic fluid flows out of port A through the balance valve, when the hydraulic system is standby, no fluid flows into port B, balance valve closed, motor will continue to rotate because of the load inertia, hydraulic fluid circulates through the motor by internal orifice of balance valve, the rotatry speed decreases slowly and finally stop. The high pressure relief valves play the role of motor overload protection.

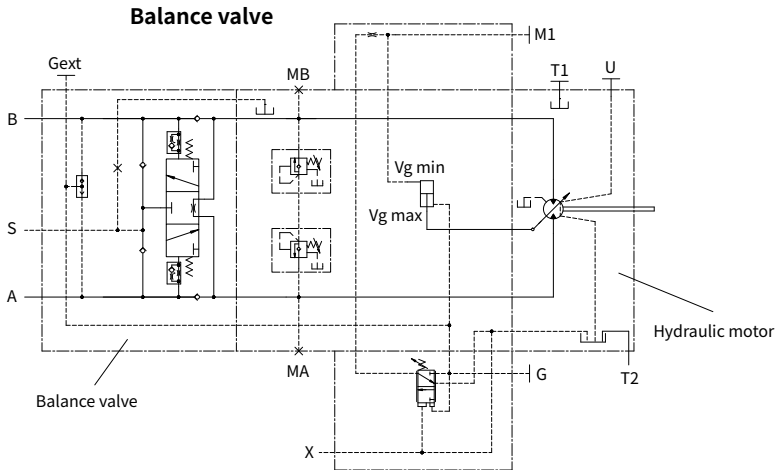

## Principle (With Counter Balance Valve )

### · HA2T3+BVD (Automatic High Pressure Related Control + Remote Pressure control + Counter Balance Valve)

HA2T3BVD(Automatic High Pressure Related Control + Remote pressure control + Counter Balance Valve + Second Small Displacement Control, increment of working pressure  $\Delta P \approx 100\text{bar}$ , Spool of balance valve without internal orifice, control system has high pressure relief valves.)

For the HA2T3 control mode, in spite of working pressure from A or B port will provide the control valve pressure, the beginning of control can be influenced by applying a pilot pressure to port X. The beginning of control is reduced by 17 bar per 1 bar pilot pressure.

S port is boost port, boost hydraulic fluid can reduce the risk that motor vacuums during braking. When the motor is working (fluid flows from port B to port A), balance valve opened, hydraulic fluid flows out of port A through the balance valve, when the hydraulic system is standby, no fluid flows into port B, balance valve closed, second small displacement control valve opened, hydraulic fluid pushes the piston of second small displacement control, motor displacement changes from the minimum to the larger displacement ( $<$  maximum displacement), preventing the motor from stalling and sucking out. The high pressure relief valves play the role of motor overload protection.

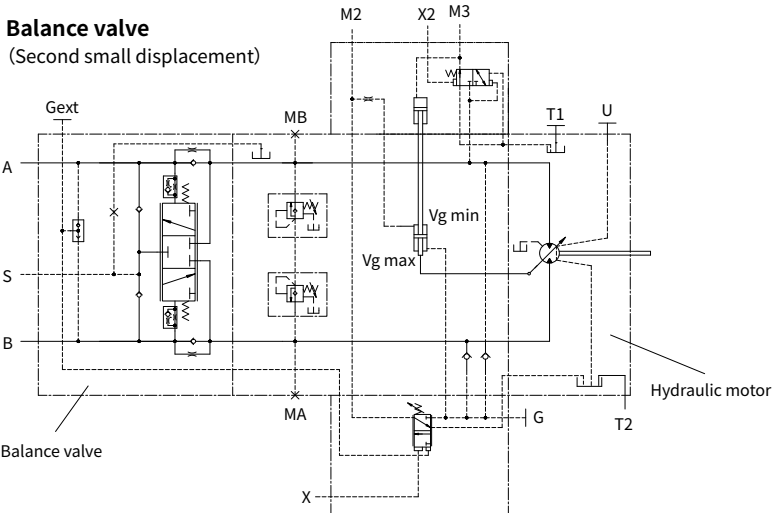

# Installation size

## M60VE28 Installation size

Plug-in motor

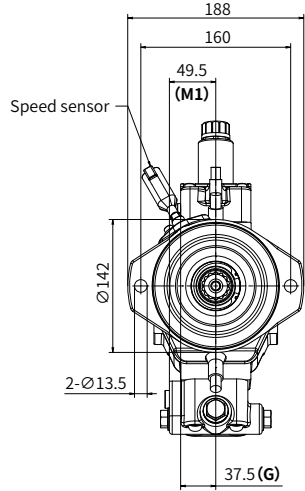
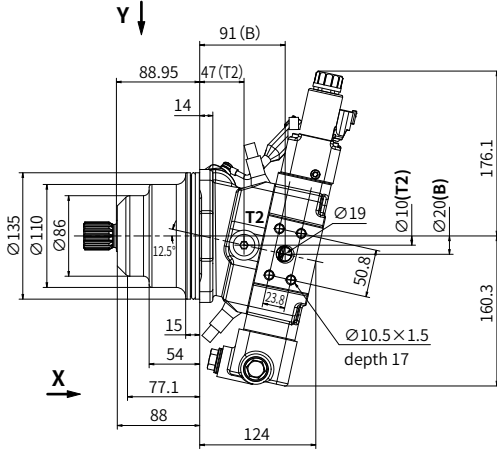

**X View**

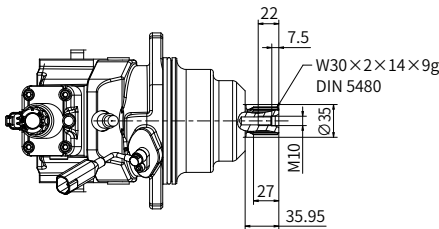

**Y View**

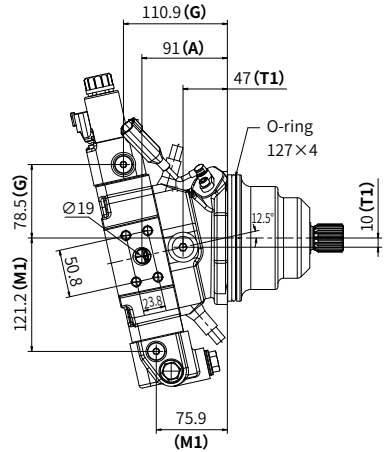

04

## Installation size

### · M60VE28 Direction of rotation and oil flow direction

Installation	Rotation
Flow A → B	Clockwise
Flow B → A	Counter-clockwise

### · M60VE28 Port details

	Port name	Port size and description	Tightening torque (N · m)
A, B	Inlet port and Delivery port	SAE J518 3/4" M10×1.5 (depth17mm)	57
T1	Case drain port	ISO 9974 M18×1.5 (Through hole)	45
T2		ISO 9974 M18×1.5 (Through hole)	45
G	Measuring port pressure	ISO 9974 M14×1.5 (depth 11.5mm)	45
M1		ISO 9974 M14×1.5 (depth 11.5mm)	45

Port	H	M	D	α
T1	15	M18×1.5	∅ 18	90°
T2	15	M18×1.5	∅ 18	90°
G	15	M14×1.5	∅ 14	90°
M1	15	M14×1.5	∅ 14	90°

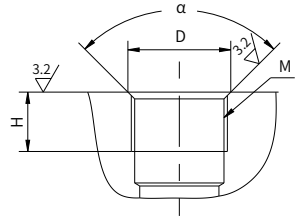

04

### · M60VE28 Input shaft type

"Z6" type shaft

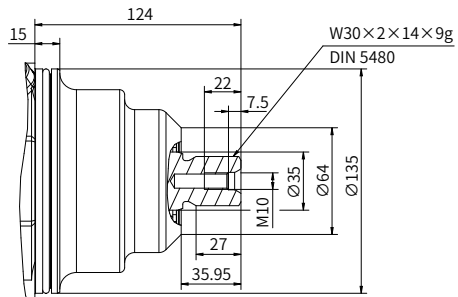

# Installation size

## M60V 60 Installation size Flange-type motor

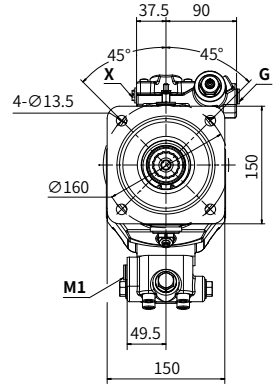
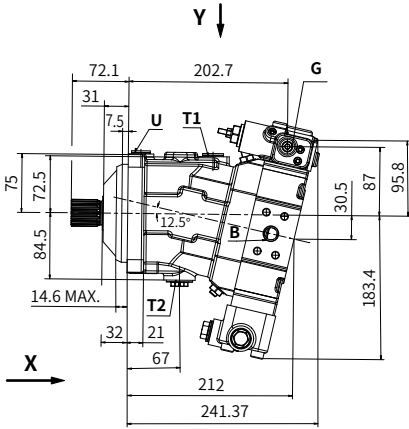

**X View**

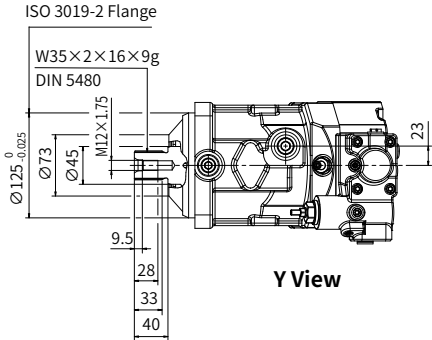

**Y View**

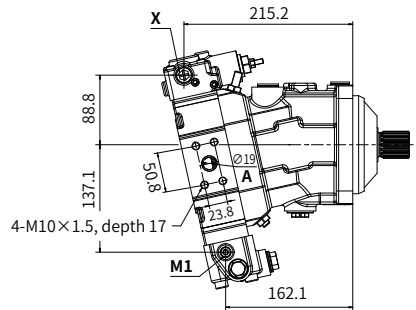

## Installation size

### • M60V 60 Direction of rotation and oil flow direction

Installation	Rotation
Flow A → B	Clockwise
Flow B → A	Counter-clockwise

### • M60V 60 Port details

	Port name	Port size and description	Tightening torque (N·m)
A, B	Inlet port and Delivery port	SAE J518 1 1/4" M10×1.5 (depth 17mm)	57
T1	Case drain port	ISO 6149 M22×1.5 (depth 15.5mm)	100
T2		ISO 6149 M27×2 (depth 19mm)	-(Plastic plug)
G	Measuring port pressure	ISO 6149 M14×1.5 (depth 11.5mm)	45
U	Flushing port	ISO 6149 M18×1.5 (depth 14.5mm)	70
M1	Measuring port pressure	ISO 6149 M14×1.5 (depth 11.5mm)	45
Sa	External flushing port	ISO 6149 M22×1.5 (depth 16.5mm)	80

Port	H	L	M	D	D1	θ
T1	15.5	2.4	M22×1.5	∅ 23.8	∅ 34	30°
T2	19	3.1	M27×2	∅ 29.4	∅ 35	30°
G	11.5	2.4	M14×1.5	∅ 15.8	∅ 22	30°
U	14.5	2.4	M18×1.5	∅ 19.8	∅ 26	30°
M1	11.5	2.4	M14×1.5	∅ 15.8	∅ 22	30°
Sa	16.5	2.4	M22×1.5	∅ 21.8	-	30°

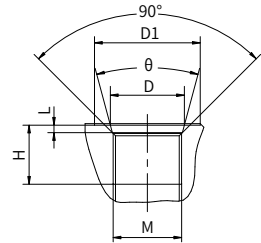

### • M60V 60 Input shaft type

"Z8" type shaft

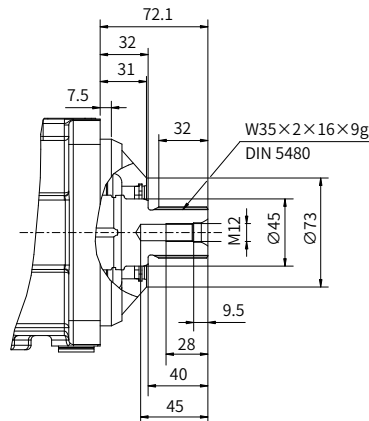



# Installation size

## M60VE60 Installation size Plug-in motor

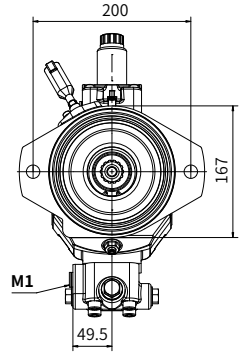
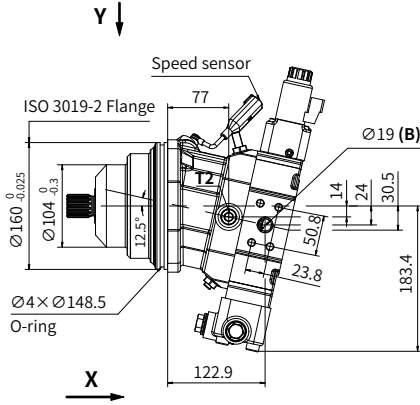

X View

W30×2×14×9g  
DIN5480

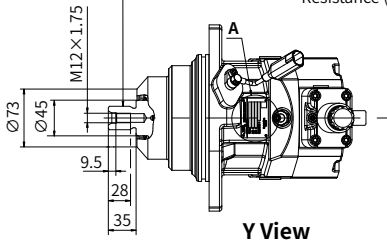

Y View

Deutsch DT04-2P  
Rated voltage: 24V  
Control current: 200~600mA  
Resistance (@20°C): 21.7 $\Omega$

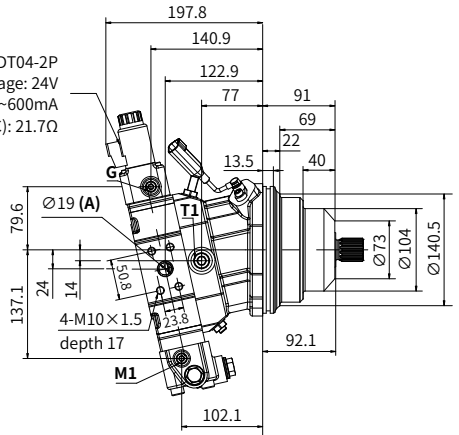

## Installation size

### · M60VE60 Direction of rotation and oil flow direction

Installation	Rotation
Flow A → B	Clockwise
Flow B → A	Counter-clockwise

### · M60VE60 Port details

	Port name	Port size and description	Tightening torque (N·m)
A, B	Inlet port and Delivery port	SAE J518 3/4" M10×1.5 (depth 17mm)	57
T1	Case drain port	ISO 6149 M22×1.5 (Through hole)	100
T2		ISO 6149 M22×1.5 (Through hole)	100
G	Measuring port pressure	ISO 6149 M14×1.5 (depth 11.5mm)	45
M1		ISO 6149 M14×1.5 (depth 11.5mm)	45

Port	H	L	M	D	D1	θ
T1	19	2.4	M22×1.5	∅ 23.8	∅ 34	30°
T2	19	2.4	M22×1.5	∅ 23.8	∅ 34	30°
G	11.5	2.4	M14×1.5	∅ 15.8	∅ 22	30°
M1	11.5	2.4	M14×1.5	∅ 15.8	∅ 22	30°

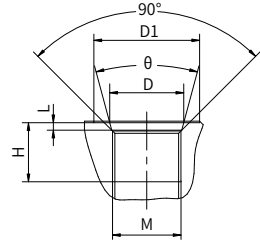

04

### · M60VE60 Input shaft type

"Z6" type shaft

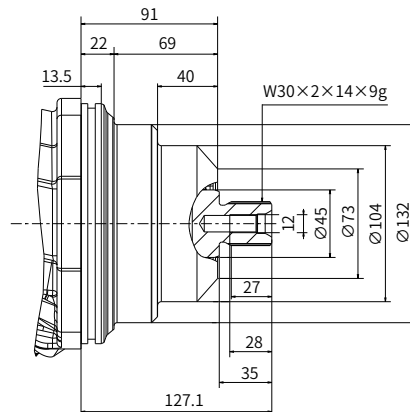

# Installation size

## M60V 85 Installation size Flange-type motor

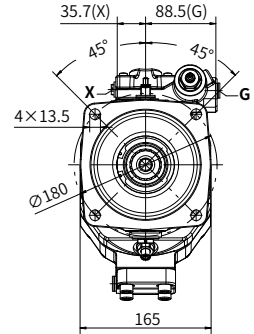
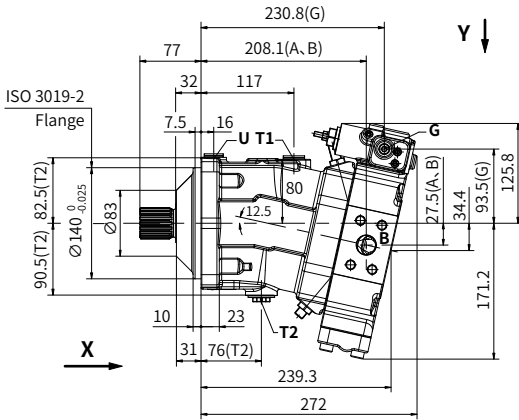

**X View**

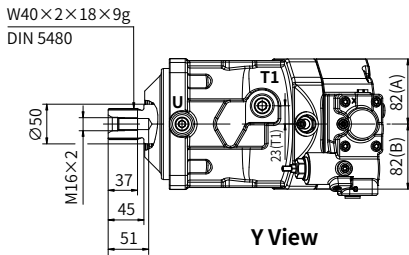

**Y View**

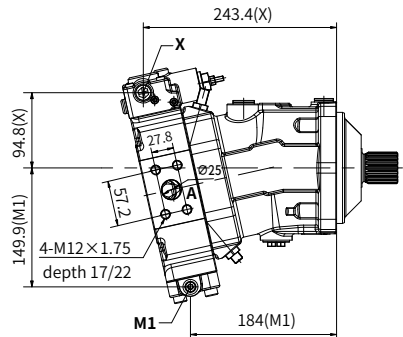

04

## Installation size

### · M60V 85 Direction of rotation and oil flow direction

Installation	Rotation
Flow A → B	Clockwise
Flow B → A	Counter-clockwise

### · M60V 85 Port details

	Port name	Port size and description	Tightening torque (N·m)
A, B	Inlet port and Delivery port	SAE J518 1" M12×1.75 (depth 17mm)	98
T1	Case drain port	ISO 6149 M22×1.5 (depth 15.5mm)	45
T2		ISO 6149 M27×2 (depth 19mm)	210
G	Measuring port	ISO 6149 M14×1.5 (depth 11.5mm)	45
U	Flushing port	ISO 6149 M18×1.5 (depth 14.5mm)	45
X	Pilot port	ISO 6149 M14×1.5 (depth 11.5mm)	45
M1	Measuring port	ISO 6149 M14×1.5 (depth 11.5mm)	45

Port	H	L	M	D	D1	θ
T1	15.5	2.4	M22×1.5	∅ 23.8	∅ 30	30°
T2	19	3.1	M27×2	∅ 29.4	∅ 34	30°
G	11.5	2.4	M14×1.5	∅ 15.8	∅ 22	30°
U	14.5	2.4	M18×1.5	∅ 19.8	∅ 28	30°
X	11.5	2.4	M14×1.5	∅ 15.8	∅ 22	30°
M1	11.5	2.4	M14×1.5	∅ 15.8	-	30°

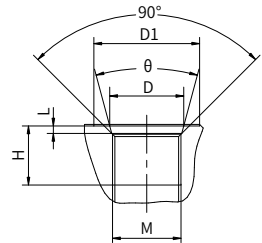

### · M60V 85 Input shaft type

"Z9" type shaft

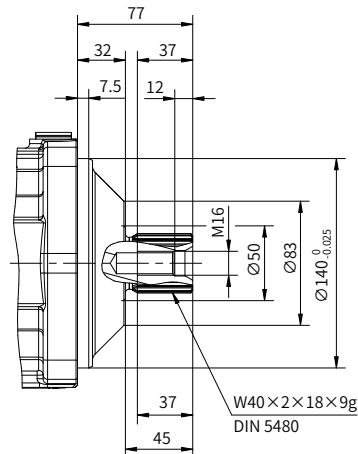



## Installation size

### • M60VE85 Direction of rotation and oil flow direction

Installation	Rotation
Flow A → B	Clockwise
Flow B → A	Counter-clockwise

### • M60VE85 Port details

	Port name	Port size and description	Tightening torque (N·m)
A, B	Inlet port and Delivery port	SAE J518 1" M12×1.75 (depth 17mm)	98
T1	Case drain port	ISO 6149 M22×1.5 (depth 15.5mm)	45
T2		ISO 6149 M22×1.5 (depth 15.5mm)	45
G	Measuring port	ISO 6149 M14×1.5 (depth 11.5mm)	45
M1		ISO 6149 M14×1.5 (depth 11.5mm)	45

Port	H	L	M	D	D1	θ
T1	15.5	2.4	M22×1.5	∅ 23.8	∅ 29	30°
T2	15.5	2.4	M22×1.5	∅ 23.8	∅ 29	30°
G	11.5	2.4	M14×1.5	∅ 15.8	∅ 22	30°
M1	11.5	2.4	M14×1.5	∅ 15.8	∅ 22	30°

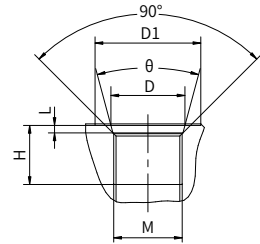

### • M60VE85 Input shaft type

"Z9" type shaft

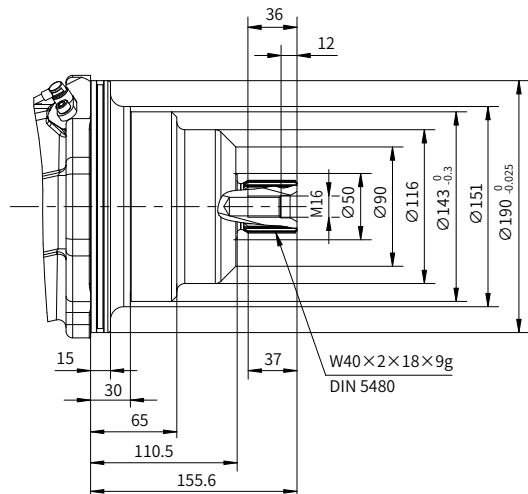

# Installation size

**M60V 85 Installation size** Flange-type motor,  
With balance valve

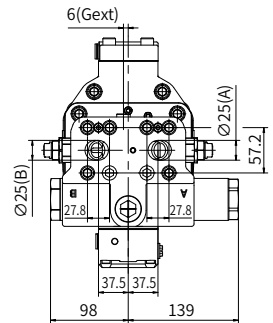
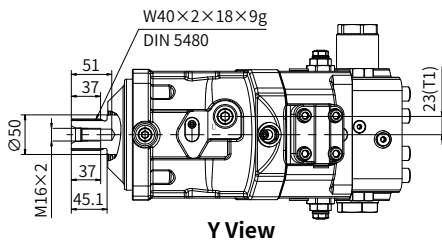
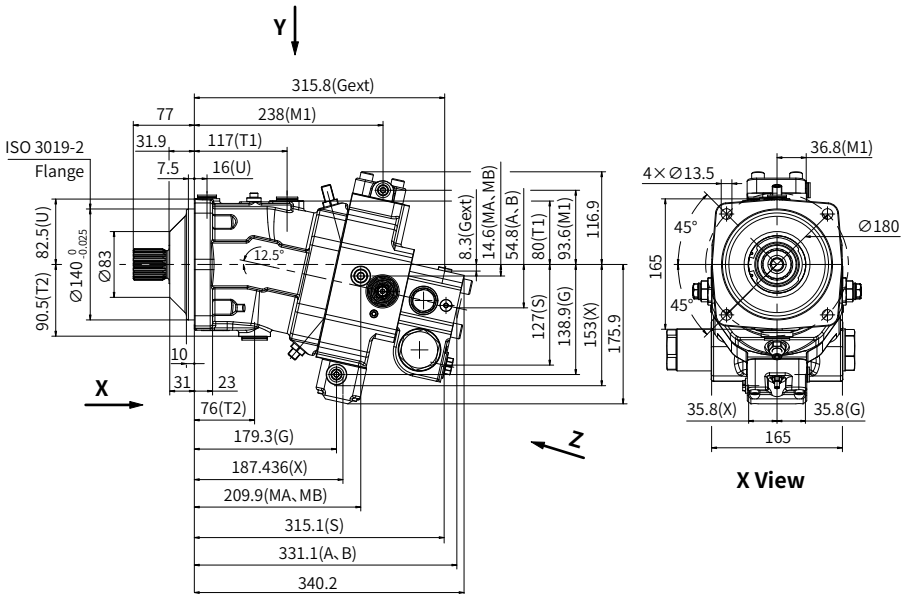

• **Direction of rotation and oil flow direction**

Installation	Rotation
Flow A → B	Clockwise
Flow B → A	Counter-clockwise

## Installation size

### • M60V 85 Port details

	Port name	Port size and description	Tightening torque (N·m)
A, B	Inlet port and Delivery port	SAE J518 1 in	98
U	Bearing flushing	ISO 6149 M18×1.5 (depth 14.5mm)	45
T1	Case drain port	ISO 6149 M22×1.5 (depth 15.5mm)	60
T2		ISO 6149 M27×2 (depth 19mm)	100
MA, MB	Measuring port	ISO 6149 M18×1.5 (depth 14.5mm)	70
M1		ISO 6149 M14×1.5 (depth 11.5mm)	45
G	Synchronous control	ISO 6149 M14×1.5 (depth 11.5mm)	45
X	Pilot port	ISO 6149 M14×1.5 (depth 11.5mm)	45
S	Charge port	DIN 3852 M22×1.5 (depth 14mm)	100
Gext	Brake release port	DIN 3852 M12×1.5 (depth 12.5mm)	22

Port	H	L	M	D	D1	θ
U	14.5	2.4	M18×1.5	∅ 19.8	∅ 28	30°
T1	15.5	2.4	M22×1.5	∅ 23.8	∅ 30	30°
T2	19	3.1	M27×2	∅ 29.4	∅ 34	30°
MA, MB	14.5	2.4	M18×1.5	∅ 19.8	∅ 28	30°
M1	11.5	2.4	M14×1.5	∅ 15.8	-	30°
G	11.5	2.4	M14×1.5	∅ 15.8	∅ 22	30°
X	11.5	2.4	M14×1.5	∅ 15.8	∅ 22	30°
S	14	2.4	M22×1.5	∅ 23.8	∅ 30	30°
Gext	12.5	1.5	M12×1.5	∅ 13.8	∅ 19	30°

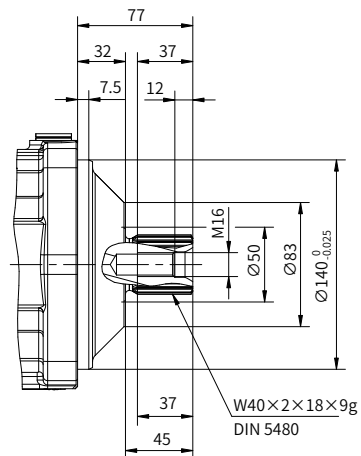
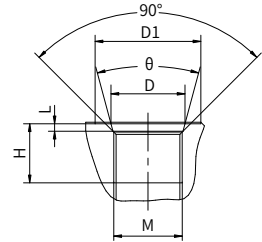

### • M60V 85 Input shaft type

"Z9" type shaft



# Installation size

## M60V 115 Installation size Flange-type motor

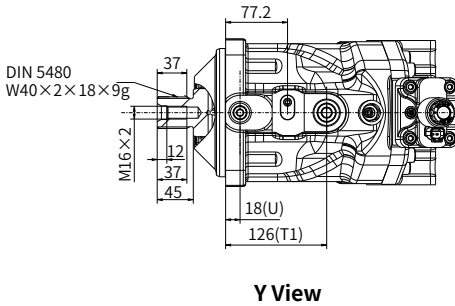
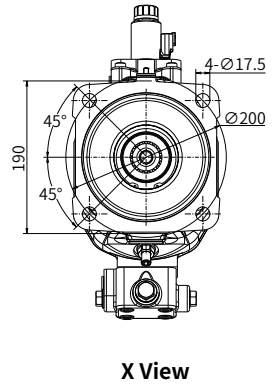
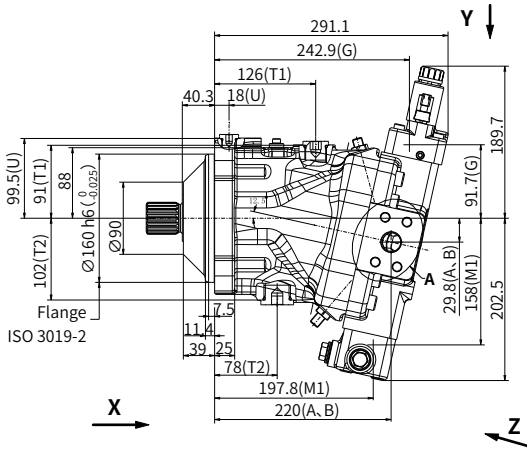

Deutsch DT04-2P  
 Rated voltage: 24V  
 Control current: 200~600mA  
 Resistance(@20°C): 21.7Ω

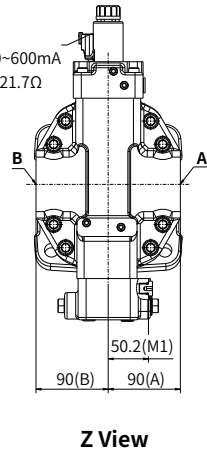

04

## Installation size

### · M60V 115 Direction of rotation and oil flow direction

Installation	Rotation
Flow A → B	Clockwise
Flow B → A	Counter-clockwise

### · M60V 115 Port details

	Port name	Port size and description	Tightening torque (N·m)
A, B	Inlet port and Delivery port	SAE J518 1" M12×1.75 (depth 17mm)	98
T1	Case drain port	ISO 6149 M27×2 (depth 19mm)	90
T2		ISO 6149 M33×2 (depth 19mm)	120
G	Measuring port	ISO 6149 M14×1.5 (depth 11.5mm)	45
U	Flushing port	ISO 6149 M18×1.5 (depth 14.5mm)	45
X	Pilot port	ISO 6149 M14×1.5 (depth 11.5mm)	45
M1	Measuring port	ISO 6149 M14×1.5 (depth 11.5mm)	45

Port	H	L	M	D	D1	θ
T1	19	3.1	M27×2	∅ 29.4	∅ 34	30°
T2	19	3.1	M33×2	∅ 35.4	∅ 43	30°
G	11.5	2.4	M14×1.5	∅ 15.8	∅ 22	30°
U	14.5	2.4	M18×1.5	∅ 19.8	∅ 28	30°
X	11.5	2.4	M14×1.5	∅ 15.8	∅ 22	30°
M1	11.5	2.4	M14×1.5	∅ 15.8	∅ 22	30°

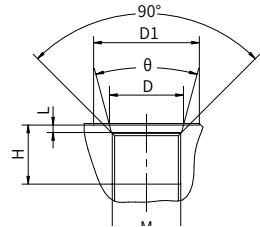

### · M60V 115 Input shaft type

"Z9" type shaft

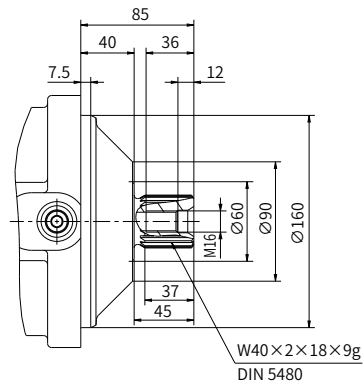

# Installation size

## M60V 115 Installation size SAE Flange-type motor

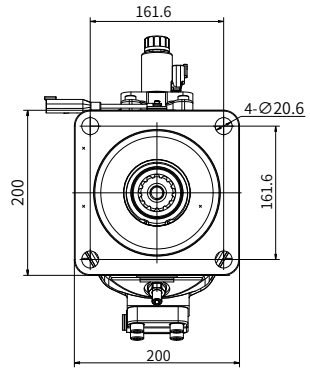
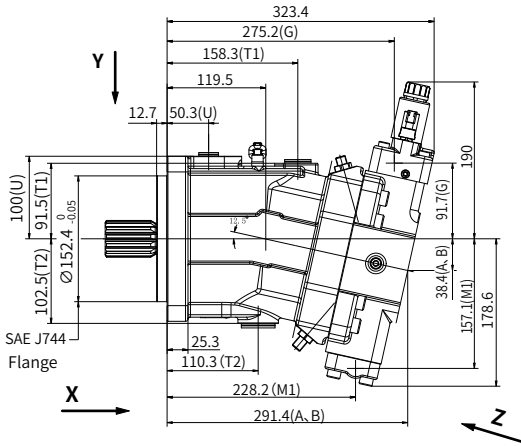

X View

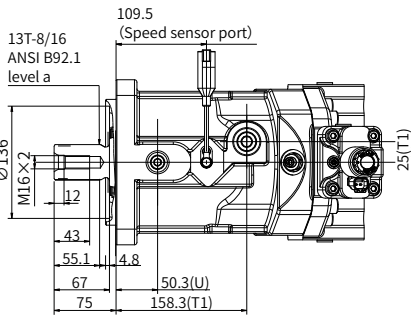

Y View

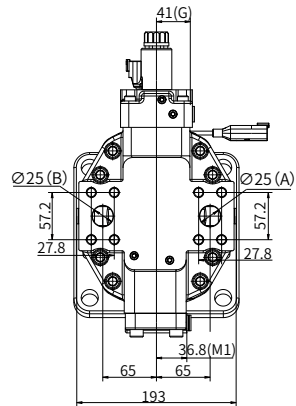

Z View

## Installation size

### • M60V 115 Direction of rotation and oil flow direction

Installation	Rotation
Flow A → B	Clockwise
Flow B → A	Counter-clockwise

### • M60V 115 Port details

	Port name	Port size and description	Tightening torque (N · m)
A, B	Inlet port and Delivery port	SAE J518 1" M12 × 1.75 (depth 17mm)	98
T1	Case drain port	ISO 6149 M27 × 2 (depth 19mm)	90
T2		ISO 6149 M33 × 2 (depth 19mm)	120
G	Measuring port	ISO 6149 M14 × 1.5 (depth 11.5mm)	45
U	Flushing port	ISO 6149 M18 × 1.5 (depth 14.5mm)	45
X	Pilot port	ISO 6149 M14 × 1.5 (depth 11.5mm)	45
M1	Measuring port	ISO 6149 M14 × 1.5 (depth 11.5mm)	45

Port	H	L	M	D	D1	θ
T1	19	3.1	M27 × 2	∅ 29.4	∅ 34	30°
T2	19	3.1	M33 × 2	∅ 35.4	∅ 43	30°
G	11.5	2.4	M14 × 1.5	∅ 15.8	∅ 22	30°
U	14.5	2.4	M18 × 1.5	∅ 19.8	∅ 28	30°
X	11.5	2.4	M14 × 1.5	∅ 15.8	∅ 22	30°
M1	11.5	2.4	M14 × 1.5	∅ 15.8	∅ 22	30°

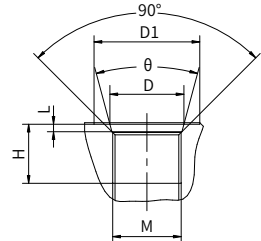

### • M60V 115 Input shaft type

"A3" type shaft

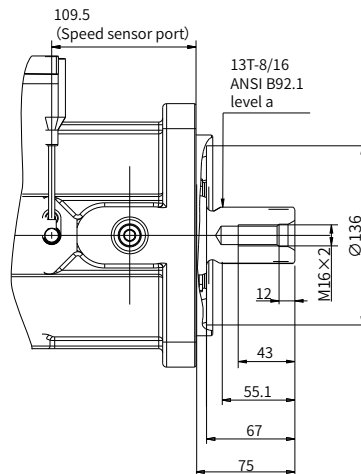

# Installation size

## M60V 115 Installation size

Flange-type motor,  
With balance valve

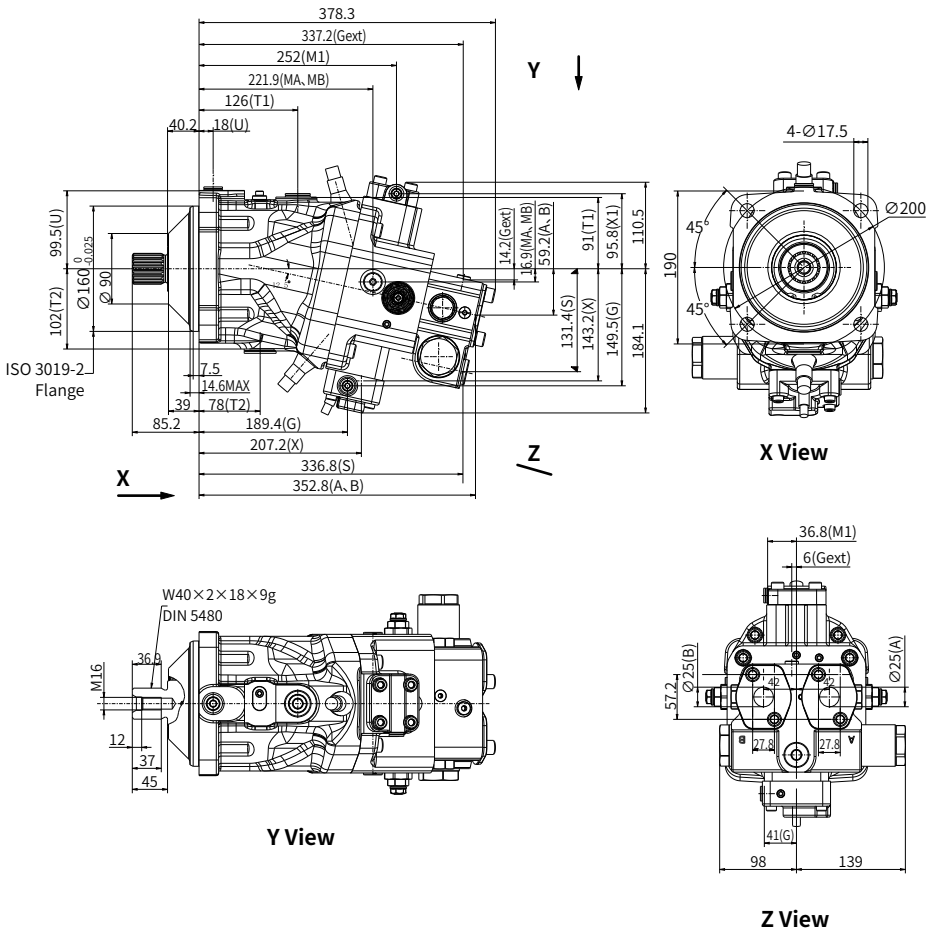

### • Direction of rotation and oil flow direction

**Installation**

Flow A → B

Flow B → A

**Rotation**

Clockwise

Counter-clockwise

## Installation size

### • M60V 115 Port details

	Port name	Port size and description	Tightening torque (N·m)
A, B	Inlet port and Delivery port	SAE J518 1 in	98
U	Bearing flushing	ISO 6149 M18×1.5 (depth 14.5mm)	45
TI	Case drain port	ISO 6149 M27×2 (depth 19mm)	100
T2		ISO 6149 M33×2 (depth 19mm)	160
MA, MB	Measuring port	ISO 6149 M18×1.5 (depth 14.5mm)	70
M2, M3		ISO 6149 M10×1 (depth 11.5mm)	15
G	Synchronous control	ISO 6149 M14×1.5 (depth 11.5mm)	45
X, X2	Pilot port	ISO 6149 M14×1.5 (depth 11.5mm)	45
S	Charge port	ISO 9974 M27×2 (depth 16mm)	170
Gext	Brake release port	ISO 9974 M12×1.5 (depth 12.5mm)	22

Port	H	L	M	D	D1	θ
U	14.5	2.4	M18×1.5	∅ 19.8	∅ 28	30°
TI	19	3.1	M27×2	∅ 29.4	∅ 34	30°
T2	19	3.1	M33×2	∅ 35.4	∅ 43	30°
MA, MB	14.5	2.4	M18×1.5	∅ 19.8	∅ 28	30°
M2, M3	11.5	1	M10×1	∅ 11.1	∅ 16	24°
G	11.5	2.4	M14×1.5	∅ 19.8	∅ 28	30°
X, X2	11.5	2.4	M14×1.5	∅ 15.8	∅ 22	30°
S	16	3.1	M27×2	∅ 29.4	∅ 34	30°
Gext	12.5	1.5	M12×1.5	∅ 13.8	∅ 19	30°

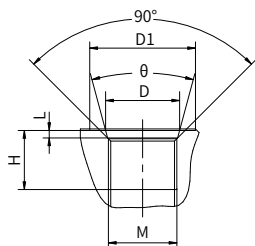

04

### • M60V 115 Input shaft type

"Z9" type shaft

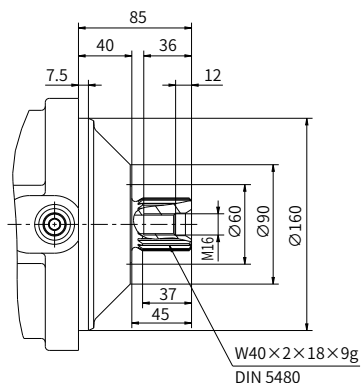

# Installation size

## M60V 160 Installation size Flange-type motor

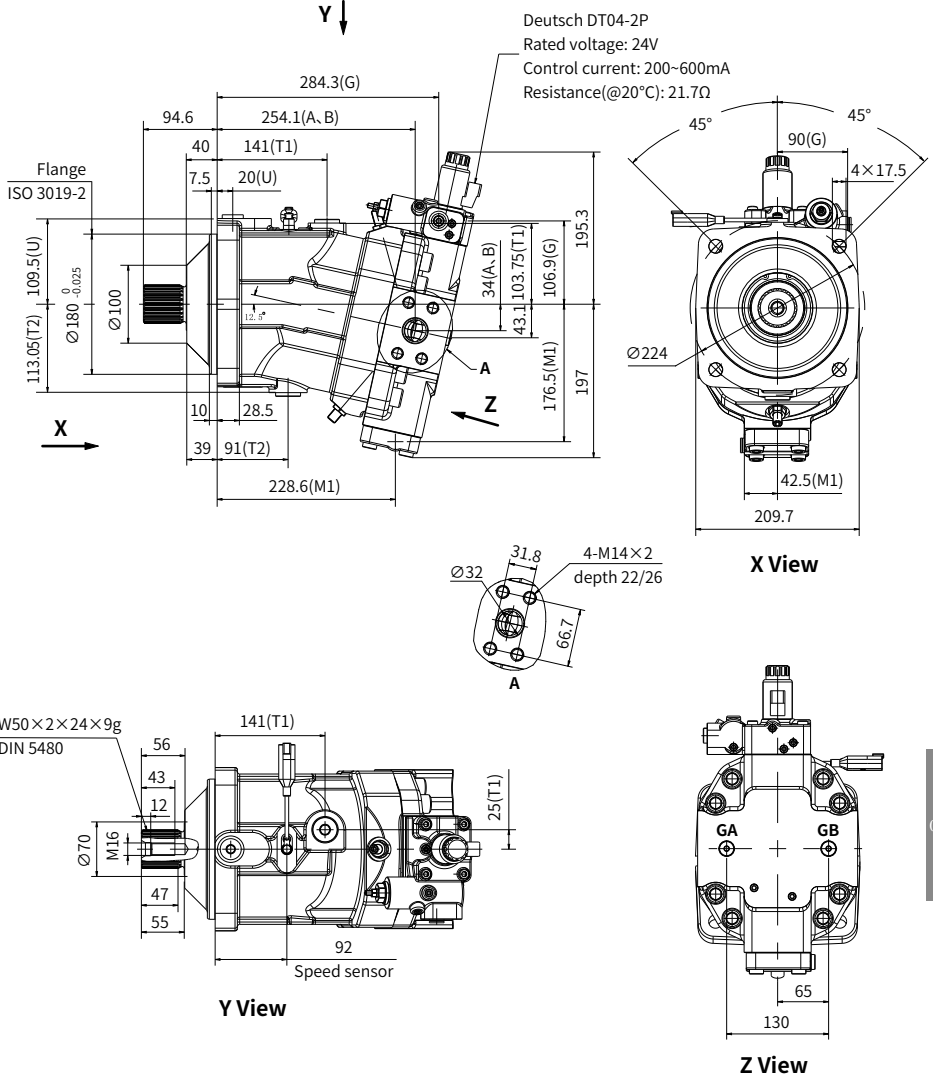

04

## Installation size

### · M60V 160 Direction of rotation and oil flow direction

Installation	Rotation
Flow A → B	Clockwise
Flow B → A	Counter-clockwise

### · M60V 160 Port details

	Port name	Port size and description	Tightening torque (N·m)
A, B	Inlet port and Delivery port	SAE J518 1 1/4" M14×2 (depth 19mm)	-
T1	Case drain port	DIN 3852 M26×1.5 (depth 23mm ED seals)	110±10
T2		DIN 3852 M26×1.5 (depth 18mm ED seals)	110±10
G	Measuring port	DIN 3852 M14×1.5 (depth 15mm ED seals)	40±5
U	Flushing port	DIN 3852 M22×1.5 (depth 20mm ED seals)	45±5
GA, GB	Measuring port	DIN 3852 M14×1.5 (depth 12mm ED seals)	40±5

Port	H	M	D	α
T1	23	M26×1.5	∅ 26	90°
T2	18	M26×1.5	∅ 26	90°
G	15	M14×1.5	∅ 14	90°
U	20	M22×1.5	∅ 22	90°
GA, GB	12	M14×1.5	∅ 14	90°

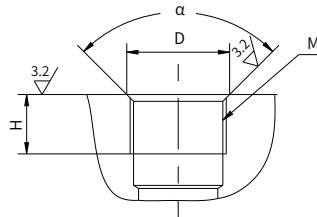

### · M60V 160 Input shaft type

"A1" type shaft

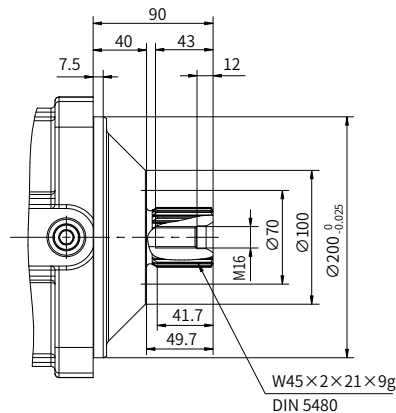



# Installation size

## M60V 170 Installation size Flange-type motor

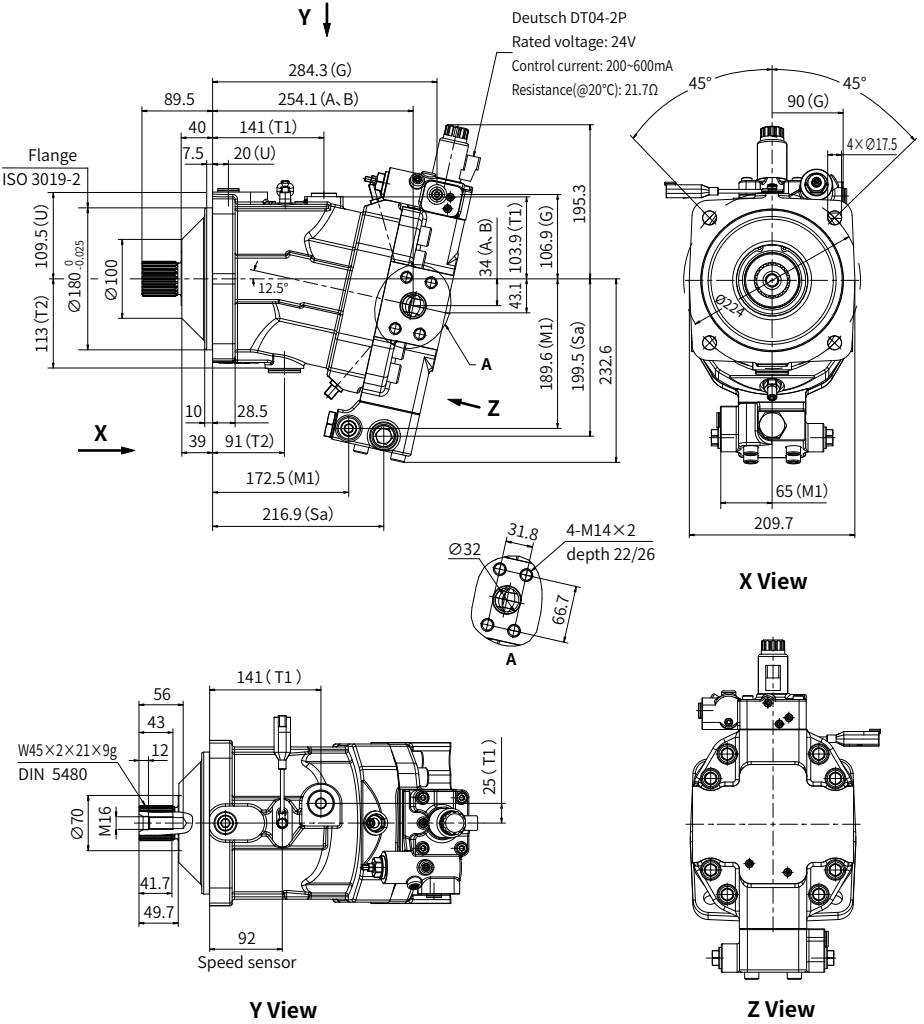

04

## Installation size

### • M60V 170 Direction of rotation and oil flow direction

Installation	Rotation
Flow A → B	Clockwise
Flow B → A	Counter-clockwise

### • M60V 170 Port details

	Port name	Port size and description	Tightening torque (N·m)
A, B	Inlet port and Delivery port	SAE J518 1 1/4" M14×2 (depth 22mm)	157
T1	Case drain port	ISO 6149 M27×2 (depth 29mm)	210
T2		ISO 6149 M33×2 (depth 25.5mm)	215
G	Measuring port pressure	ISO 6149 M14×1.5 (depth 11.5mm)	45
U	Flushing port	ISO 6149 M22×1.5 (depth 20mm)	45
M1	Measuring port pressure	ISO 6149 M14×1.5 (depth 12.5mm)	45
Sa	External flushing port	ISO 6149 M22×1.5 (depth 16mm)	100

Port	H	L	M	D	D1	θ
T1	29	3.1	M27×2	∅ 29.4	∅ 34	30°
T2	25.5	3.1	M33×2	∅ 35.4	∅ 43	30°
G	11.5	2.4	M14×1.5	∅ 15.8	∅ 25	30°
U	20	2.4	M22×1.5	∅ 23.8	∅ 29	30°
M1	12.5	2.4	M14×1.5	∅ 15.8	∅ 22	30°
Sa	16	2.4	M22×1.5	∅ 23.8	∅ 30	30°

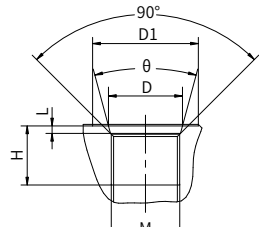

### • M60V 170 Input shaft type

"A1" type shaft

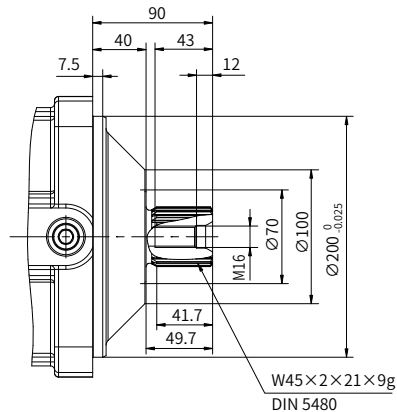

# Installation size

**M60V 170 Installation size** Plug-in motor,  
With balance valve

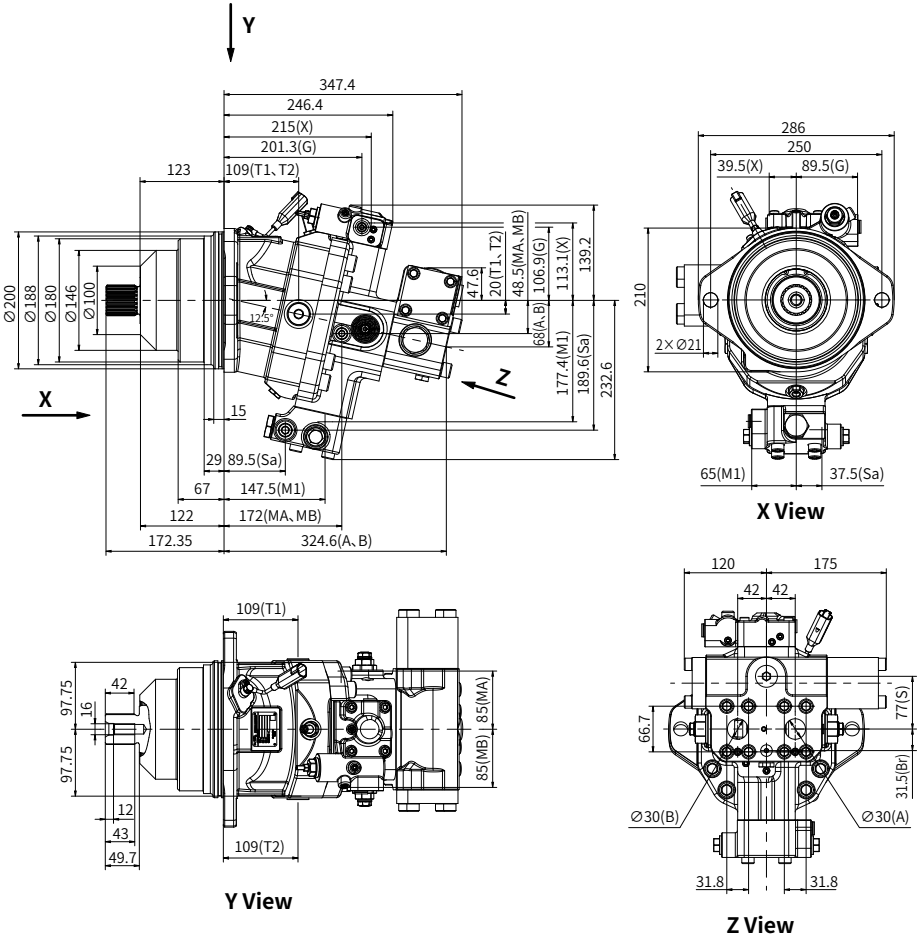

• **Direction of rotation and oil flow direction**

Installation	Rotation
Flow A → B	Clockwise
Flow B → A	Counter-clockwise

## Installation size

### • M60V 170 Port details

	Port name	Port size and description	Tightening torque (N·m)
A, B	Inlet port and Delivery port	SAE J518 1 1/4"	157
	Fastening thread	DIN 13 M14×2 (depth 19mm)	157
T1, T2	Case drain port	ISO 6149 M27×2 (depth 19mm)	100
MA, MB	Measuring port	ISO 6149 M18×1.5 (depth 14.5mm)	70
M1		ISO 6149 M14×1.5 (depth 11.5mm)	45
G	Synchronous control	ISO 6149 M14×1.5 (depth 11.5mm)	45
X	Pilot port	ISO 6149 M14×1.5 (depth 11.5mm)	45
Sa	Flushing port	ISO 6149 M22×1.5 (depth 16.5mm)	100
S	Charge port	ISO 9974 M27×2 (depth 16mm)	170
Br	Brake release port	ISO 9974 M12×1.5 (depth 12mm)	22

Port	H	L	M	D	D1	θ
T1, T2	19	3.1	M27×2	∅ 29.4	∅ 34	30°
MA, MB	14.5	2.4	M18×1.5	∅ 19.8	∅ 28	30°
M1	11.5	2.4	M14×1.5	∅ 15.8	∅ 25	30°
G	11.5	2.4	M14×1.5	∅ 15.8	∅ 25	24°
X	11.5	2.4	M14×1.5	∅ 15.8	∅ 25	30°
Sa	16.5	2.4	M22×1.5	∅ 23.8	∅ 30	30°
S	16	3.1	M27×2	∅ 29.4	∅ 34	30°
Br	12	1.5	M12×1.5	∅ 13.8	∅ 19	30°

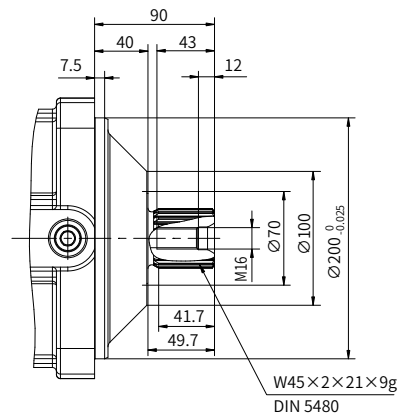
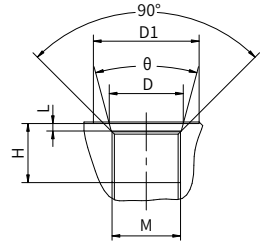

### • M60V 170 Input shaft type

"A1" type shaft

# Installation size

## M60V 200 Installation size Flange-type motor

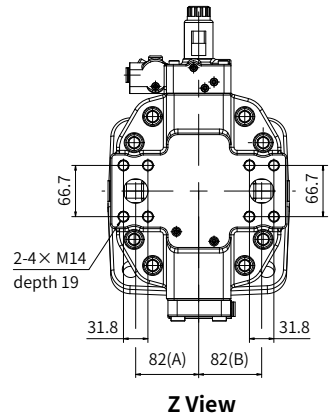
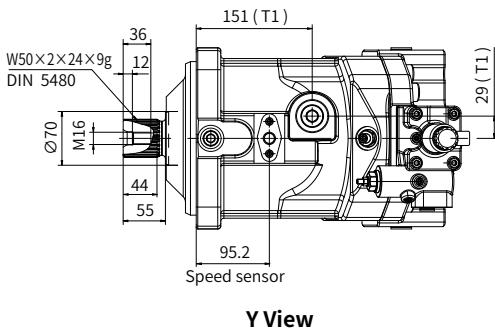
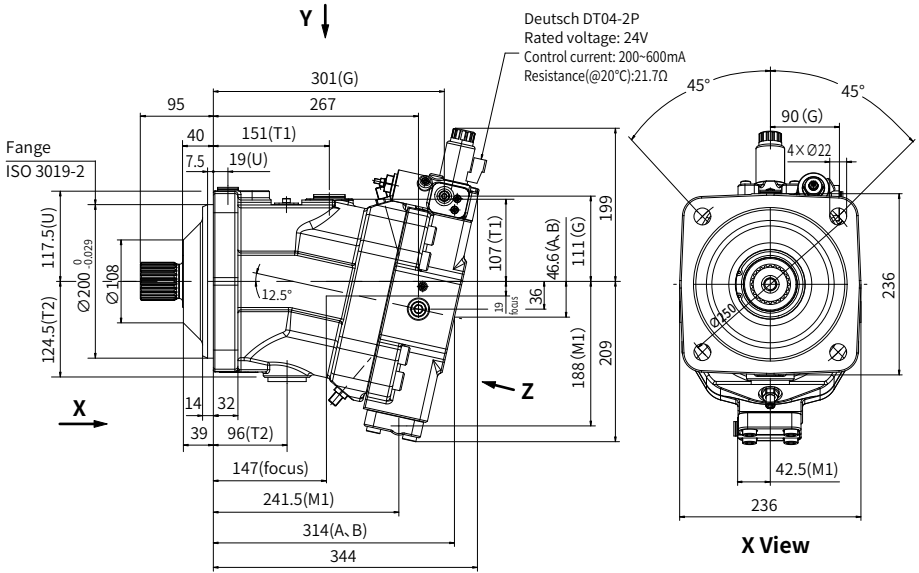

04

## Installation size

### · M60V 200 Direction of rotation and oil flow direction

Installation	Rotation
Flow A → B	Clockwise
Flow B → A	Counter-clockwise

### · M60V 200 Port details

	Port name	Port size and description	Tightening torque (N·m)
A, B	Inlet port and Delivery port	SAE J518 1 1/4" M14×2 (depth 20mm)	157
T1	Case drain port	ISO 6149 M33×2 (depth 20mm)	215
T2		ISO 6149 M42×2 (depth 20mm)	330
G	Measuring port pressure	ISO 6149 M14×1.5 (depth 11.5mm)	45
U	Flushing port	ISO 6149 M22×1.5 (depth 11.5mm)	45
M1	Measuring port pressure	ISO 6149 M14×1.5 (depth 11.5mm)	45

Port	H	L	M	D	D1	θ
T1	20	3.1	M33×2	∅ 35.4	∅ 43	30°
T2	20	3.1	M42×2	∅ 44.4	∅ 52	30°
G	11.5	2.4	M14×1.5	∅ 15.8	∅ 25	30°
U	11.5	2.4	M22×1.5	∅ 23.8	∅ 34	30°
M1	11.5	2.4	M14×1.5	∅ 15.8	-	30°

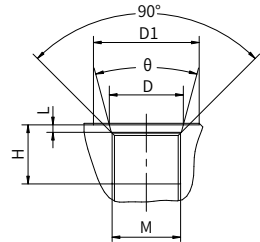

### · M60V 200 Input shaft type

"A2" type shaft

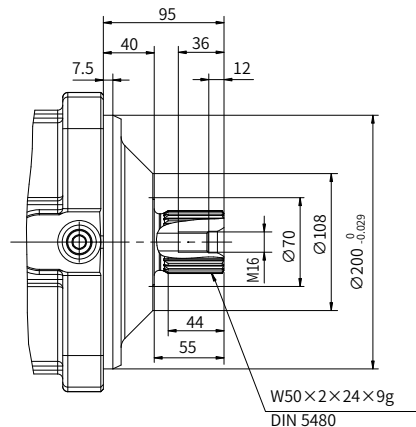

# Installation size

## M60V 215 Installation size

Flange-type motor

Deutsch DT04-2P  
 Rated voltage: 24V  
 Control current: 200-600mA  
 Resistance(@20°C):21.7Ω

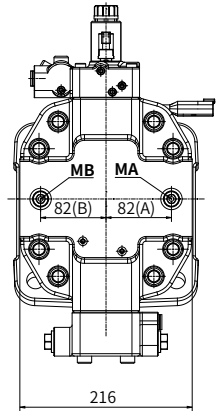
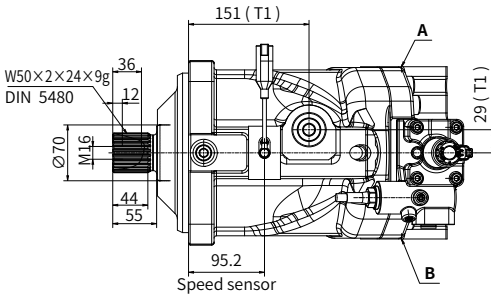
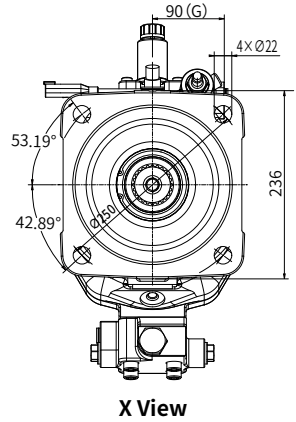
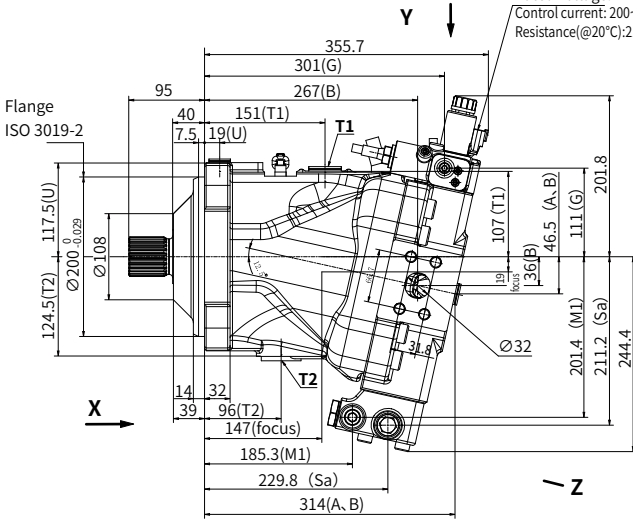

04

## Installation size

### • M60V 215 Direction of rotation and oil flow direction

Installation	Rotation
Flow A → B	Clockwise
Flow B → A	Counter-clockwise

### • M60V 215 Port details

	Port name	Port size and description	Tightening torque (N·m)
A, B	Inlet port and Delivery port	SAE J518 1 1/4" M14×2 (depth 20mm)	157
T1	Case drain port	ISO 6149 M33×2 (depth 20mm)	215
T2		ISO 6149 M42×2 (depth 20mm)	330
G	Measuring port	ISO 6149 M14×1.5 (depth 11.5mm)	45
U	Flushing port	ISO 6149 M22×1.5 (depth 11.5mm)	45
M1	Measuring port	ISO 6149 M14×1.5 (depth 11.5mm)	45

Port	H	L	M	D	D1	θ
T1	20	3.1	M33×2	∅ 35.4	∅ 43	30°
T2	20	3.1	M42×2	∅ 44.4	∅ 52	30°
G	11.5	2.4	M14×1.5	∅ 15.8	∅ 25	30°
U	11.5	2.4	M22×1.5	∅ 23.8	∅ 34	30°
M1	11.5	2.4	M14×1.5	∅ 15.8	-	30°

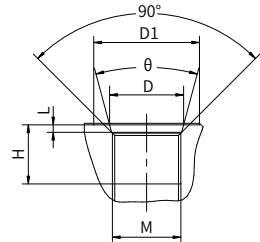

### • M60V 215 Input shaft type

"A2" type shaft

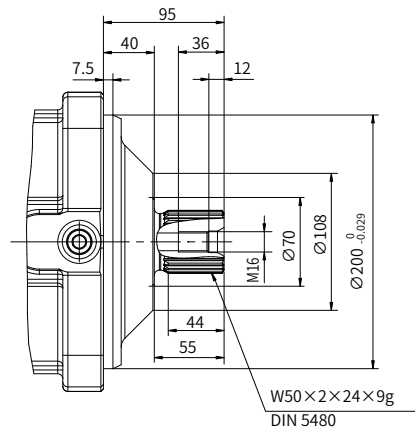





**China**

+86 400 101 8889

**America**

+01 630 995 3674

**Germany**

+49 (30) 72088-0

**Japan**

+81 03 6809 1696



© This brochure can be reproduced, edited, reproduced or transmitted electronically without the authorization of Hengli Hydraulic Company. Due to the continuous development of the product, the information in this brochure is not specific to the specific conditions or applicability of the industry, thus, Hengli does not take any responsibility for any incomplete or inaccurate description.



4.2

# HM3V SERIES

## Axial Piston Variable Displacement Motor

HM3V series swash plate axial piston motor adopts disassembling type design, small volume, light weight, Compact installation space, applied to the open or closed hydraulic transmission circuits.

Apply to open or close circuit

Size:	25	38	45
Nominal pressure (bar):	210	210	175
Max pressure (bar):	415	415	350



### Contents

Technical Data	02
Type introduction	03
Section view	04
Principle	05
Installation size	
· HM3V 38/45 Installation size	06
· Direction of rotation and oil flow direction	07
· Port details	07
· Input shaft type	09

### Features

- Swash plate axial piston motor for open or close circuit.
- Cartridge design, compact installation space, convenient and wheel installed applications.
- Integration of two variable motor, servo variable piston, can set the minimum displacement of the motor.
- Motor oil mouth concentrate in a side, easy to install and oil circuit layout.
- High cliometric efficiency